

NGN@Home and Smart House

COPRAS meeting

Brussels October 14, 2004

Milan Erbes

ETSI AT-N WG Chairman

What is a Next Generation Network?

NGN means different to different parts of the Industry...

So which definition is correct?

“A public packet based communication network integrating voice, data and enhanced multimedia services with the following characteristics:

- ◆ **Layered instead of monolithic architecture**
- ◆ **Open standard interfaces between the layers and all other networks**
- ◆ **Seamless control of multiple transport technologies**
- ◆ **Use of standards based components ”**

NGN motivating point:

It enables New Services and therefore New Revenues...

ETSI -The NGN goals

The Next Generation Network will eventually provide:

- **A multi-service multi-protocol, multi-access, IP based network that is secure, reliable and trusted**
 - **Multi-services:** delivered by a common QoS enabled core network
 - **Multi-access:** diverse access networks; fixed and mobile terminals
 - **Not one network,** but different networks that seamlessly interoperate
- **An enabler for Service Providers to offer**
 - real-time and non real-time, communication services
 - between peers, or in a client-server configuration
- **Mobility / Nomadicity**
 - for both users and devices
 - intra and inter-Network Domains, between Fixed and Mobile networks
- **Interactive “My communications services”**
 - anywhere, any terminal, anytime

ETSI NGN Roadmap

Towards a converged of a Wireline and Wireless NGN

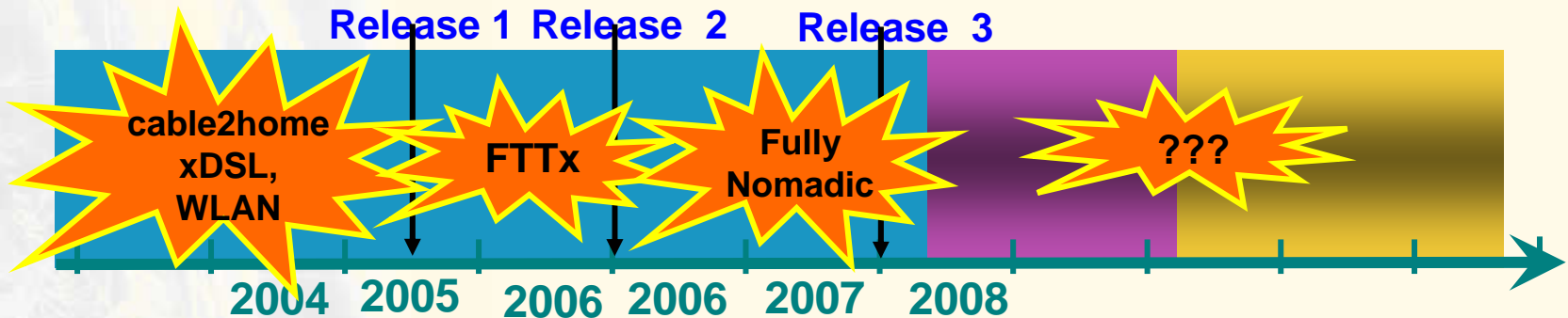

❑ Release 1 brings Multimedia services

- Intra-domain nomadicity/user-controlled roaming
- Based on use of Access network Attachment Subsystem

❑ Release 2 dynamically optimizing resources usage

- According to user subscription profile and service use

❑ Release 3 introduce a full Nomadicity

- Inter-network domain nomadicity/user-controlled roaming
- Higher bandwidth access(VDSL, Wi-max ...)

ETSI - Access activities

□ NGN@Home

- Recently launched (August 2002) with the focus on Home Networks
- To standardise the inter-work of all home technologies including Radio and fixed wireless links (TM4, BRAN)
- To facilitate common use of features in different systems

□ xDSL

- Covers the application of all DSL technologies in Europe
- Covers coexistence with legacy systems and infrastructures
- Focus on rational frequency management in the local loop

□ Cable (Telecom over CATV infrastructures)

- Covers the application of Cable technologies in Europe
- Covers lower (Euro-DOCSIS) and higher layers (Euro-IPCablecom)
- Considers the impact of convergence Telecom-Broadcast

□ PLT/ PLC

- Covers all aspects of Power Line in Europe
- Takes special care on EMC issues
- Supported by “white goods industry” aiming Home automation

NGN@Home

Terms of Reference

- ❑ **Co-operate with all parties, both internal and external to ETSI, in order to meet the objectives of NGN@Home**
- ❑ **Act as the focal point for matters related to Home Networking within TC AT and as a Project with TC TISPAN**
- ❑ **Study the interworking and compatibility between all Home Network components, in-home features and services for NGN**
- ❑ **Define the components and functions of the Home Residential Gateway (Addressing, Management, Protocols, Connectivity, QoS...) for the support of various in house applications for the reliable delivery of services to the end devices within the HAN**

NGN@Home Architecture

General Requirements

Internetworking

- Existing networks must be interconnected

Robustness

- For the loss of network or parts of it

Heterogeneity

- Consider a variety of networks including broadcast, satellite, wireless/radio and other networks

Distributed Management

- Permit distributed management of its resources

Ease of Attachment

- Permit host attachment with a low level of effort

Accountability

- Resources must be accountable

Home Networking

The objective of the project is to define and demonstrate an open network architecture enabling the provision of services to the users in its home, and in nomadic situation.

1. Build a multi-services home network based on a Residential Gateway (RG) that acts as a service platform for the end user. The RG embeds the Home Agent (HA) that allows remote management of the home network by the home network service operator.

2. Build a powerful and networked management tool. This tool is a software platform located for example in an ISP or ASP premises. This platform inter-works with the HAN.

3. Offer Remote Access (for mobility and also a visiting connection) in a secure way to the home resources via mobile phones, PDAs, laptop or workstations. This methodology will be applied for the low bit rate as well as for the high bit rate applications

Home Environment Common Items

❑ Backwards compatibility with legacy systems

- **Backwards compatibility**, support of legacy terminals features [TR 101 973 series]
- **Maximise** the usage of harmonised or converging solutions, e.g. interface offered for POTS [ES 201 970]

❑ Future oriented convergence with NGNs' evolution

- **Improve** inter-working among base technologies
- **Facilitate** differentiation & universality of services & contents

❑ Consider horizontal aspects

- **Regulatory framework** on services & networks, terminals etc
- **Interoperability** among different solutions
- **QoS** [Quality of Service] for Voice [EG 201 050]
- **Support** for emergency situations - EMTEL
- **Security** / Data Protection, Lawful Interception
- **EMC, Safety**

Home Reference Model

□ A Home Area Network:

- May be simultaneously connected to multiple and heterogeneous delivery networks
- Should ensure access to content independent of the underlying hardware / transport mechanism

□ AV Home Network Architecture

- defines the functionality and requirements for creating a local (in-room) heterogeneous AV network.

□ End users can:

- Select the service provider independent of the access mechanism
- Different end users within the same HAN can select different service providers
- Roam between delivery networks, based upon their subscription profile with the selected service provider
 - For example: a user can register with the service provider for delivery of content when connected via a neighbours' HAN

□ Define specific service needs in the following areas :

- Quality of Service (QoS)
- Security
- Privacy
- Digital Rights Management (DRM)
- Copyright ... etc.



Home Residential Gateway Architecture

RG Coordinates shared access to the Internet for all it's End Devices

Connection Module

xDSL, Cable, BWA, ETTH, FTTH...

Policy Coordination Module

Coordinates changes amongst the other modules, makes appropriate adjustments to other Modules as needed. It handles:

- IP Routing
- Digital Rights
- Multicast optimization
- NAT
- QoS
- Security

HAN Module

1. Might be separate hardware (Hub, bridge, switch, access point)
2. Ties the various home networking media together (Ethernet, IEEE 1394, 802.11, HPNA, PLC, Bluetooth, USB, Cable...)
3. Notifies the Policy Coordination Module of pertinent changes.

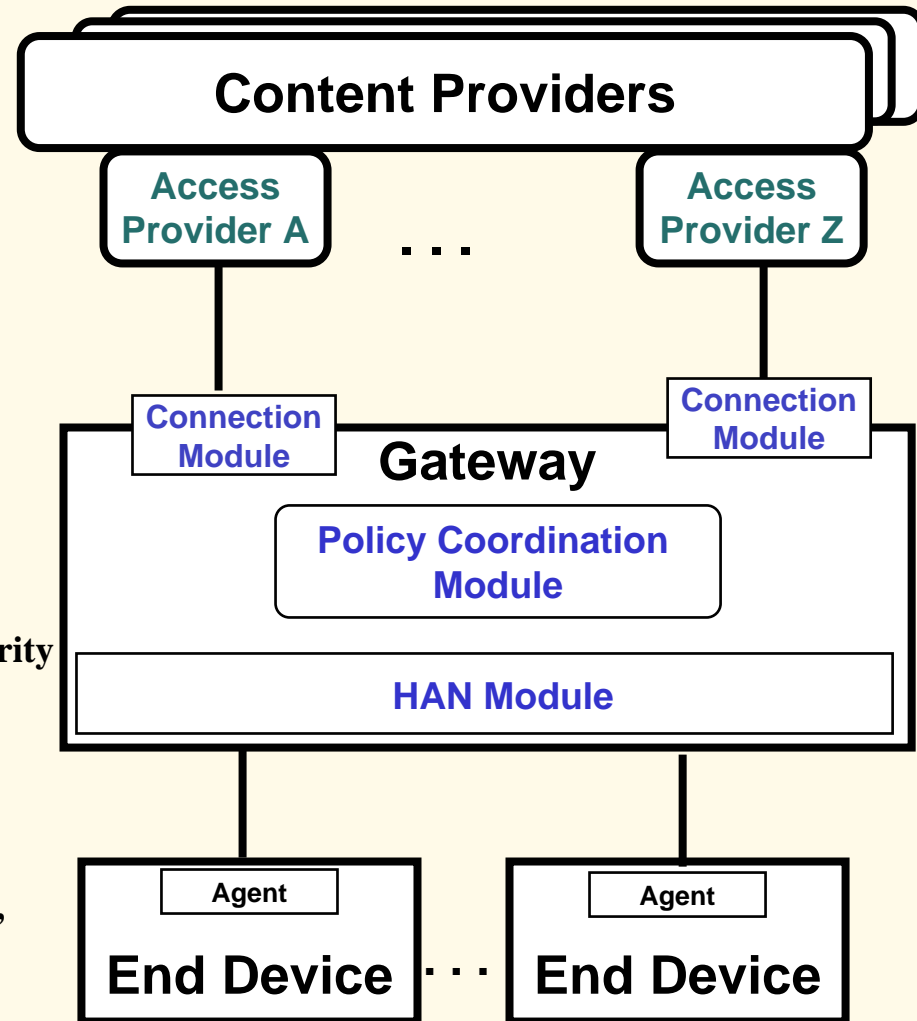

The NGN@Home viewpoint

Business Value Chain

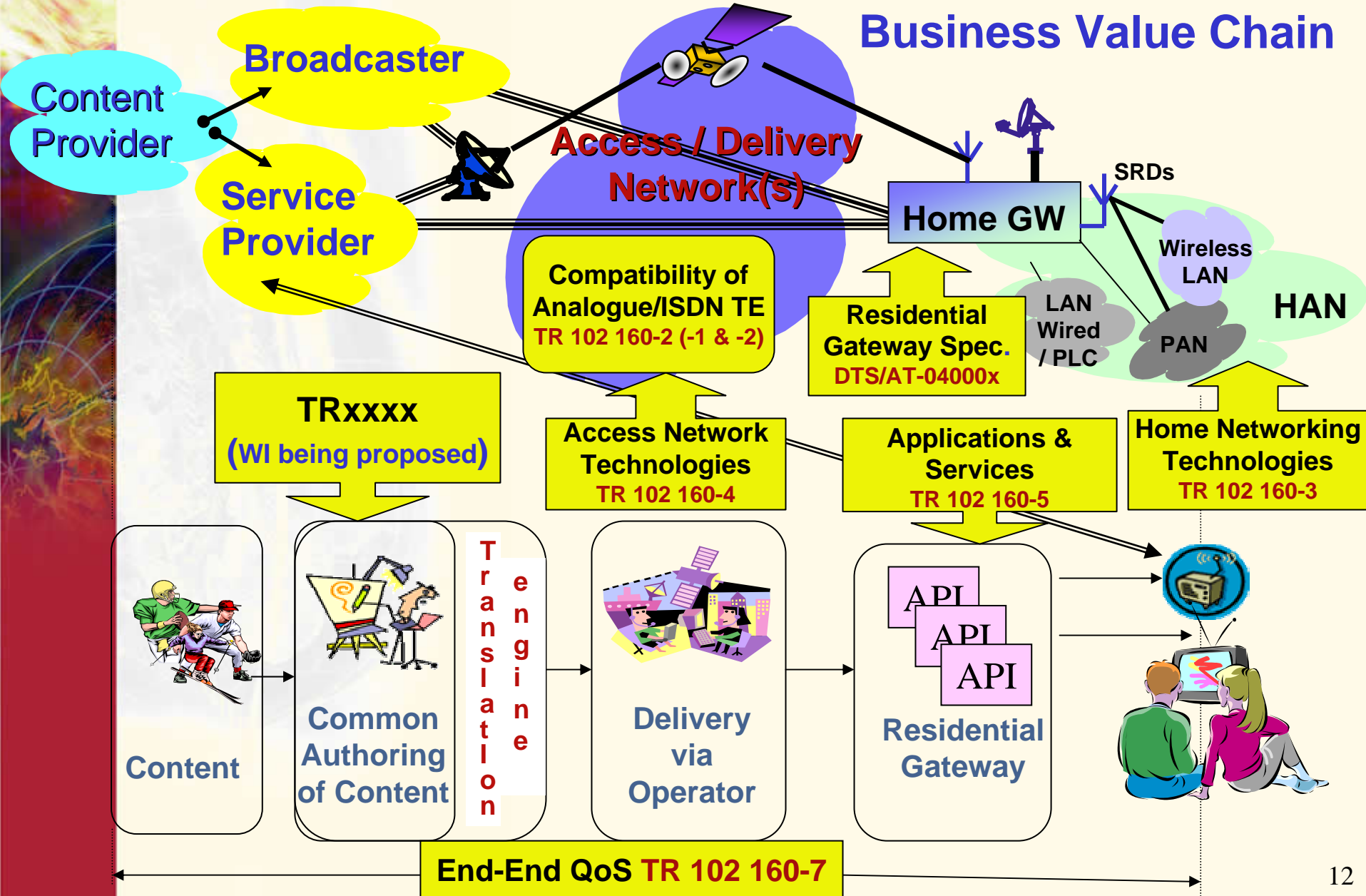

Work in the Home environment

- ❑ **TR 102 160 series (in development)**
 - Will collect the maximum information
- ❑ **Co-operation with CENELEC, ITU-T & others**
 - exist and is being intensified
 - E.g. Smart House aspects is one focus
- ❑ **Information on (wire-line) Access & Terminals**
 - Common and general aspects:
 - www.etsi.org/at
 - Specific technology aspects:
 - xDSL, Cable, Power Line

In-Home Solution

Enjoy:

Full collection of music and videos in car.
Sync over WLAN, 3G or while parked in your garage.



Connected office:

Video conferencing, VoIP, accessing information files and emails, accessing services provided in the home.

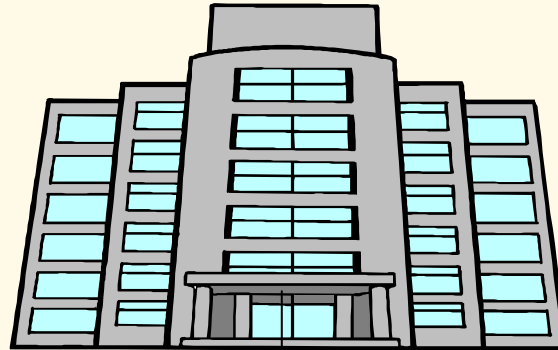

Remote Control:

Remote Managing of Home appliances. Connecting to the home network



Content:

Music
Video Games
Banking
Billing
Info-channel
TV
Chatting
Video telephony
Video Conferencing
Information Storage
Internet Radio
Messaging
Etc..



Services:

Home Appliance Control
Home Appliance Automation
Remote Management
Entertainment
Healthcare
Security
Communications
Energy Savings
Real-time E-commerce
Lighting
Shutters
Pool control
Internet
Customised solutions

Smart House Initiative

- ❑ **Smart House sets the standards for the home of the future in Europe**
- ❑ **SMH Phase II**
 - **A Code of Practice (CoP) for the Smart House**
 - **Supported by EU Commission,**
 - **Reporting to ICTSB (ICTSB/SHSSWG)**
 - **Input from all the Stakeholders**
 - **Utilizing all the standards and practical output from EU FP6 Projects**
- ❑ **Managed by CENELEC under TC 205 Ad-Hoc WG16**

SmartHouse Code of Practice

- ❑ **The Smart House CoP is to get together the Industry with the common and coherent goal**
- ❑ **Make the House of the Future a reality of today**
- ❑ **It is a CONSENSUS BUILDING initiative**
- ❑ **With the support of key players:**
 - **The Consumer (ANEC)**
 - **The Industry (DHWG, OSGi, KONNEX, CECED, Philips, Siemens, Thomson, Telecom operators, Energy providers, Installers,etc...)**
 - **The European Commission: Standardization (DG ENTR) & Research (DG INFSO)**

What will Code of Practice achieve?

- It will reference **all existing standards related to Smart House**
- It will report **the progress of ongoing standards in this area**
- It will identify **the gaps and the need for standardization**
- It will notify **eventual redundant standards and provide recommendations**
- Will provide **recommendations for interoperability**
- Will provide **recommendations based on the existing solutions**
- It will provide **a Code of Practice for the installers**
- The work started **in December 2003**
- Will be achieved **by September 2005 (20 months)**

What is NOT in the Code of Practice ?

- ❑ **Does not have a mission to create standards**
- ❑ **Will NOT make choice of selected technologies**
- ❑ **Will NOT test interoperability of each products**

SMARTHOUSE Organisation

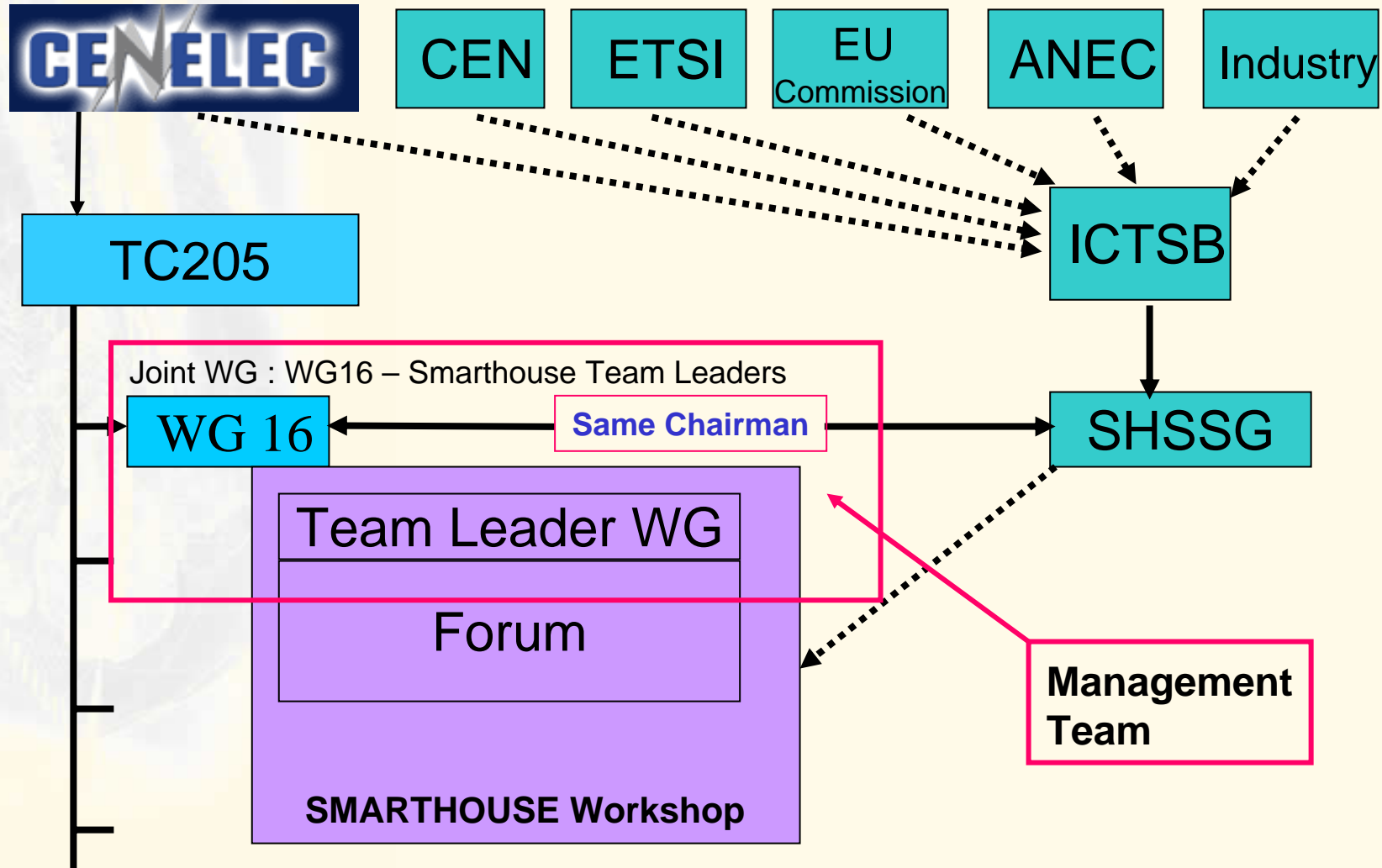

Objectives of Smart House

- Deliver a Forum for information and understanding**
- Prepare an Interim Report covering all influences**
- Prepare a Code of Practice.**
- Beyond this work, the aim is to have the CoP accepted and used in the marketplace, for it to be maintained and regularly updated.**

SmartHouse Project Sections

The subsections of the Code of Practice will cover:

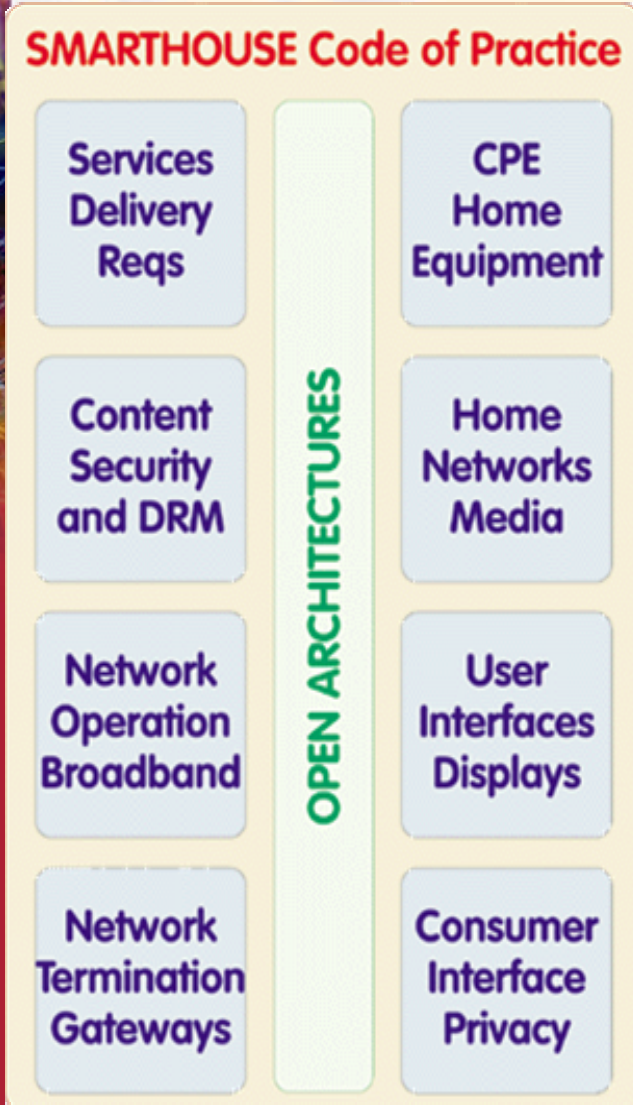

- The Service Provider aspect. Bruno Ziegler EDF
- Content, (Broad-Narrow)casting, DRM, Security, Per Kaijser - Independent
- The Network Operator Broadband delivery Alistair Munro - Bristol University
- Network Termination and Residential Gateways Milan Erbes – ETSI Independent
- Customer Premises Equipment Paolo Falcioni – CECED
- Home networks and in-home communication – Cabling, Walter von Pattay – ISO/IEC Independent
- The User Interface, A/V equipment and Displays Roger Torrenti – BIP/ Homega Research
- The Consumer interface and privacy, Roy Brooker – ANEC/Intertek
- Architectures Peter Colebrook – BSI/ i&i Limited²¹

Architecture & Gateway model

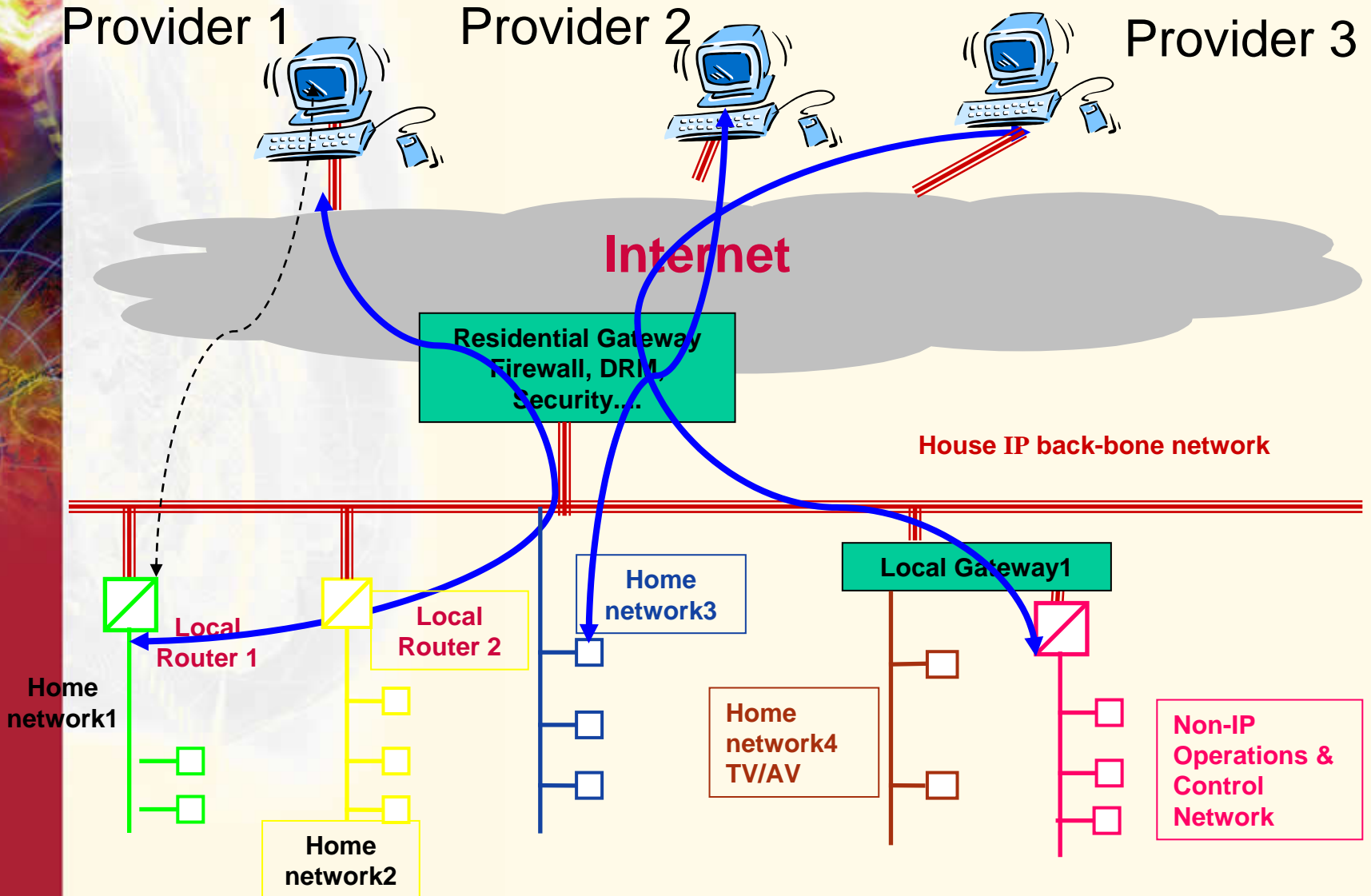

Scope - Timeframe

- ❑ **The Contract between the EU Commission and CENELEC sets a requirement for deliverables, milestones and performance indicators.**
- ❑ **Major deliverables milestone :**
 1. Roadmap for the work 19th February 2004
 2. Interim Report 19th September 2004
 3. Final Report / Code of Practice 19th August 2005
- ❑ **SmarHouse Forum:**
 - on 11 May 2004,
 - in 2005 (probably in April)
- ❑ **Work is intended to achieve a deliverable that will help the marketplace accelerate its growth in the area of SMARTHOUSEs. It also implies:**
 - Regular maintenance and upgrading of the CoP on a yearly basis in the future.

Which standards are addressed ?

- ❑ **The CoP is aimed at achieving the objectives of e-Europe 2005, when every citizen will have a range of Broadband Services.**
- ❑ **For using new services a citizen will need equipment, systems and networks in their “SmartHouses” that are:**
 - **Easy to use**, interoperable, providing intuitive interaction.
 - **Secure**, safe and conforming to open and transparent standards.
 - **Compatible** with public rules, since a significant portion of the “SmartHouses” of the future will be equipped with the help from public funds, e.g. social housing.
 - **Intuitive**, since many people are disadvantaged by disability, poor health, poor education or age.
- ❑ **Similar requirements apply for the services and applications provided by Service Providers.**

Link with Research & IST

- ❑ **CENELEC will focus on FP6 projects relevant to core activities that focus on Smart House (Home Networking) and Digital TV.**
- ❑ **Already identified several FP6 projects:**
 - **TEAHA**
 - **MEDIANET**
 - **eperspace**
 - **Pulsers**
- ❑ **Hometalk and few link to:**
 - **MHP-confidence**
 - **MHP-kdb**
 - **uni-verse**
- ❑ **Identified new FP5 projects important for SmartHouse**
 - **Euro6IX**
 - **FUTURE HOME**
 - **@HOM**
- ❑ **Smart House works closely with IPv6, with the following projects are relevant:**
 - **6NET**
 - **NGN-LAB**
 - **TORRENT end user access network**
 - **OverDrive**

Conclusions

Standardisation activities for management in Next Generation Home Networking:

- Ensure a global user approach, independent of a specific access technology**
- Define a reference architecture and network functions required to support home and/or nomadic users**
- Define required interfaces for these functions in the control layer for the terminals and the applications**



Home Residential Gateway Overview

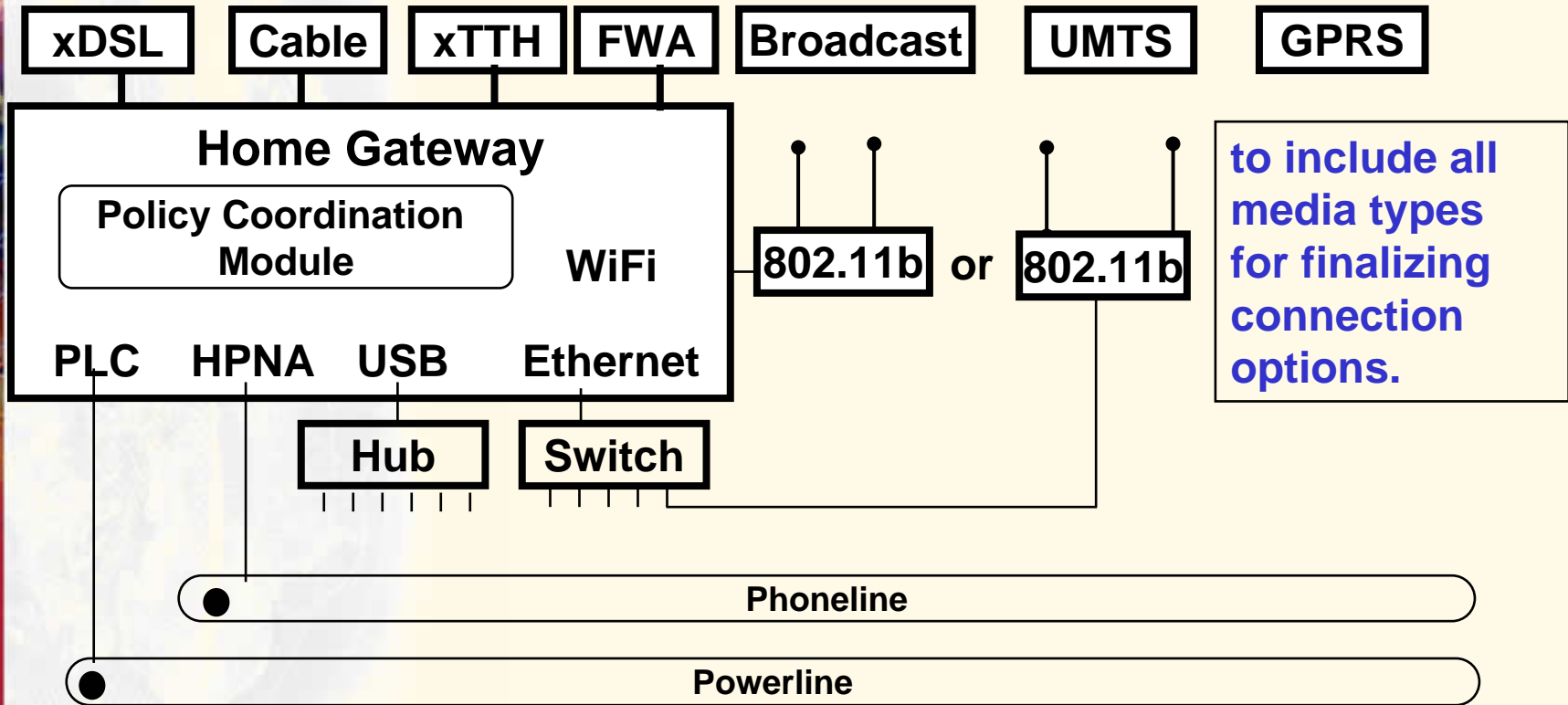

- Bridge
- USB
- Bluetooth
- 1394
- ...